

Leichtmetallgeländer
System Menziken

S 120 K

Staketengeländer
mit Stahlseileinbau



Balustrades en métal léger
système Menziken

S 120 K

Balustrade à barreaux
avec câble en acier incorporé



Leichtmetallgeländer
System Menziken

S 120 K

Staketengeländer
mit Profilhandlauf und darin
eingebautem Stahlseil

Balustrades en métal léger
système Menziken

S 120 K

Balustrade à barreaux
avec main-courante profilée et câble
en acier incorporé dedans

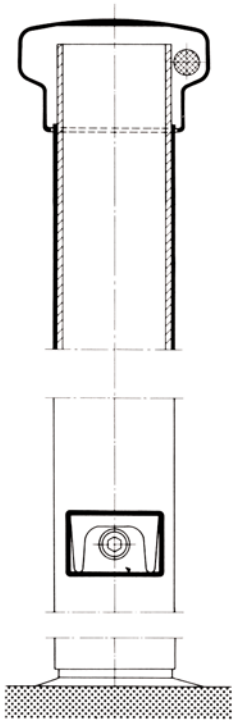
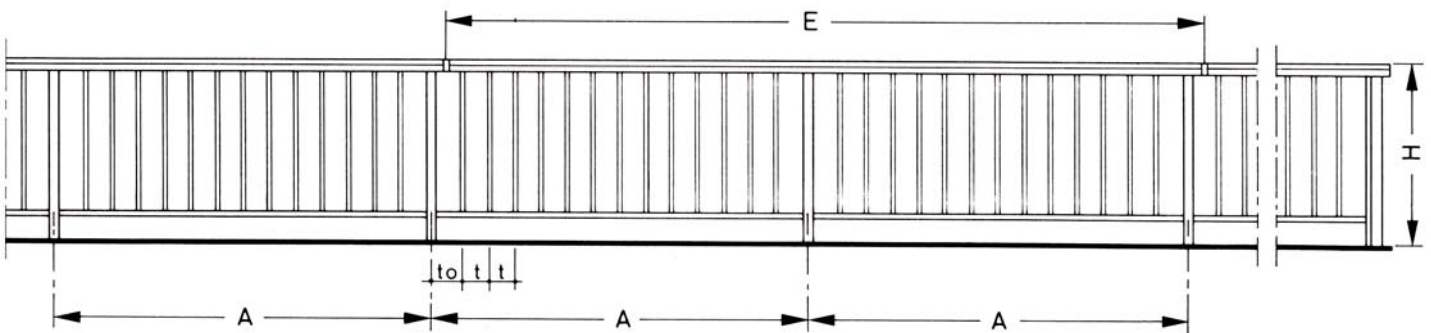

SCHNITT
COUPE A ÷ A

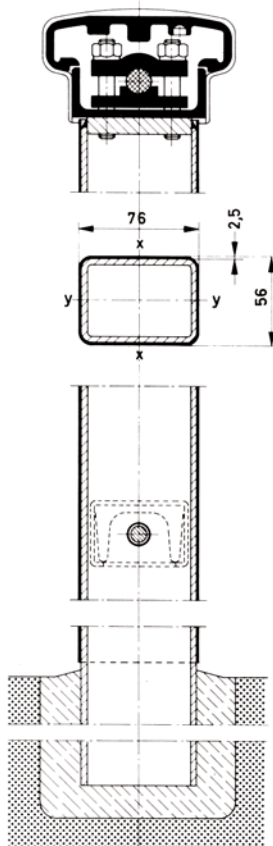

SCHNITT
COUPE B ÷ B

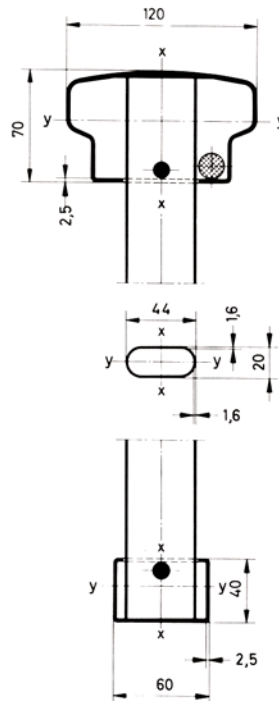

SCHNITT
COUPE C ÷ C

Normal-Abmessungen	Dimensions standards		
Geländerhöhe	Hauteur de balustrade	H	1000 mm
Pfostenabstand	Distance entre poteaux	A	2000 mm
Elementlänge	Longueur d'un élément	E	4000 mm
Staketenanzahl pro Feld	Nombre de barreaux par travée		13
Staketenabstand	Ecartement entre barreaux	t	140 mm
Staketenendabstand	Ecartement barreau/poteau	to	160 mm

Statische Werte	Valeurs statiques	J_x (mm ⁴)	J_y (mm ⁴)	W_x (mm ³)	W_y (mm ³)
Handlauf	Main-courante	130.80×10^4	67.50×10^4	22.00×10^3	17.90×10^3
Gurtprofil	Profilé de filière	23.47×10^4	12.34×10^4	7.82×10^3	6.17×10^3
Stakete	Barreau	5.44×10^4	0.67×10^4	2.47×10^3	0.67×10^3
Stahlpfosten	Poteau acier	59.50×10^4	34.63×10^4	17.00×10^3	13.85×10^3

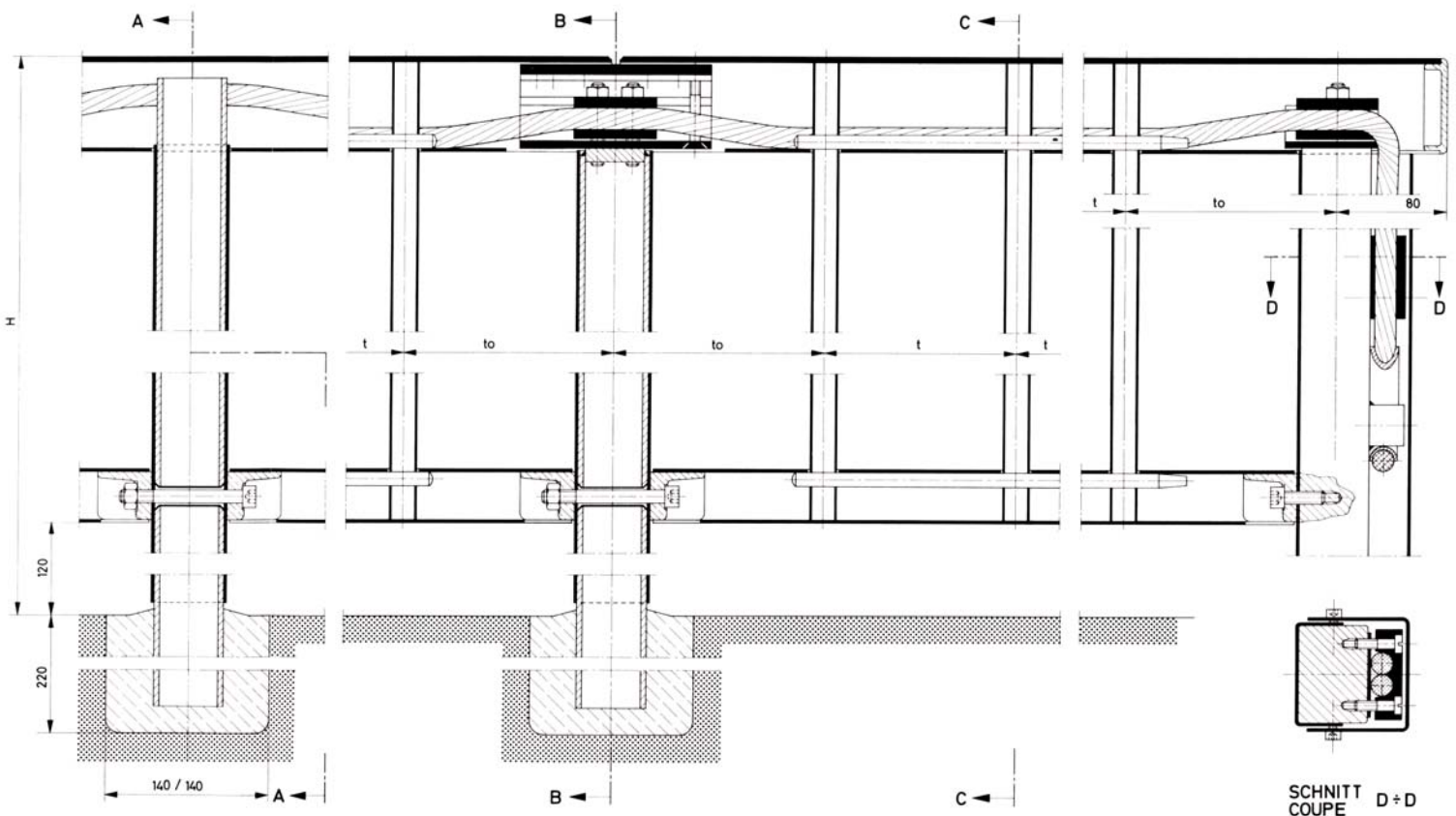

Fussplattendetails
 Détail de la plaque de fixation

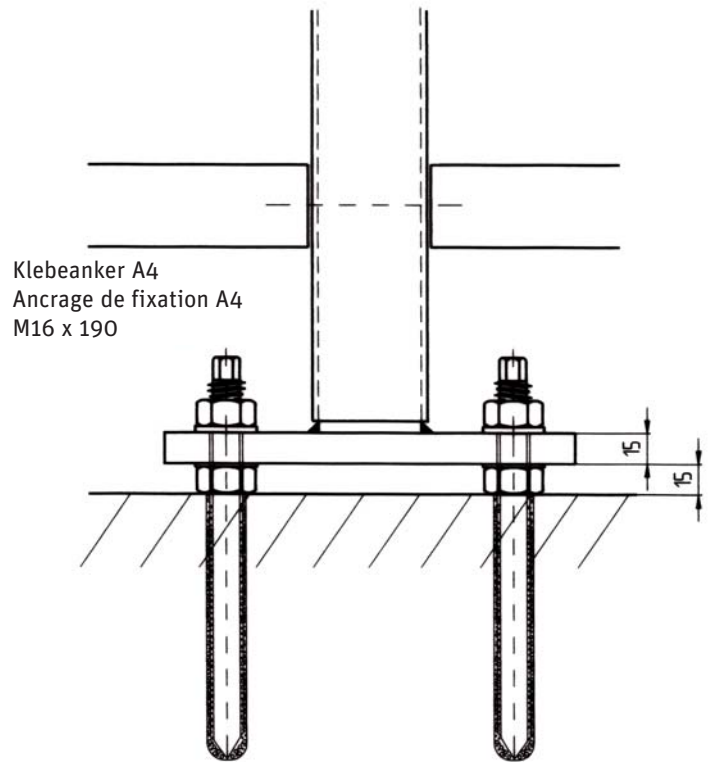
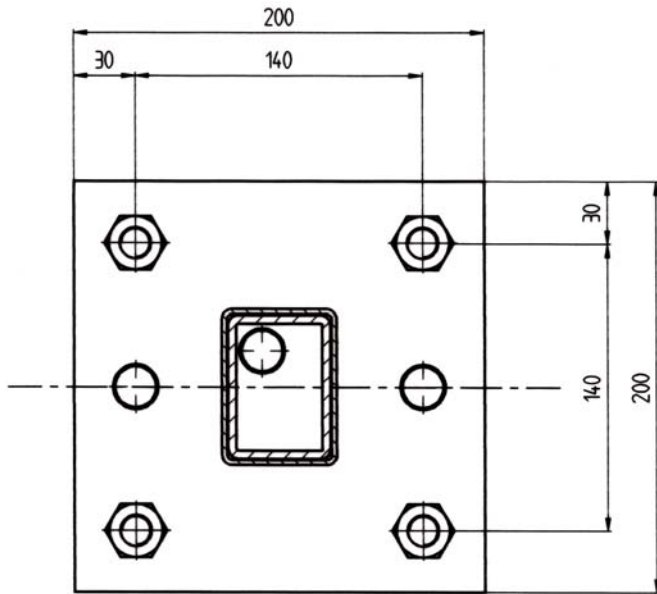

Statische Berechnung
 für Geländer-Normalausführung

Calcul statique
 pour balustrade d'exécution standard

Belastung: Charge:	Horizontale Streckenlast auf Handlauf Efforts horiz. repartis sur main-courante		p	=	1.2 N/mm
Handlauf: Main-courante:	Werkstoff: Matériaux:	EN AW-6063	σ_{zul}	=	117 N/mm ²
	Biegemoment: Flèche maximale:	$M_b = \frac{p A^2}{8}$		=	600 x 10 ³ Nmm
	Spannung: Contrainte:	$\sigma = \frac{M_b}{W_x}$		=	27 N/mm ² < σ_{zul}
Pfosten: Poteau:	Werkstoff: Matériaux:	St 52-3	σ_{zul}	=	260 N/mm ²
	Biegemoment: Flèche maximale:	$M_b = p A H$		=	2280 x 10 ³ Nmm
	Spannung: Contrainte:	$\sigma = \frac{M_b}{W_x}$		=	134 N/mm ² < σ_{zul}